

# Product Manual

---

self-service equipment

Ver 3 . 0 2022 . 10.29



# Content

Preface .....	- 2 -
15.8inch KIOSK cash register .....	- 4 -
1. Machine introduction .....	- 6 -
1. Model description .....	- 6 -
2. Features of 15.8inch KIOSK cash register .....	- 6 -
3. This product adopts an open architecture, which has many advantages .....	- 6 -
4. Configuration instruction of 15.8inch KIOSK .....	- 6 -
5. Packaging form .....	- 8 -
2. Installation Instructions .....	- 8 -
1. Introduction of machine components .....	- 8 -
2. Precautions for installation and operation .....	- 10 -
3. Driver installation .....	- 11 -
3. Self-inspection of the machine .....	- 11 -
4. Common troubleshooting methods .....	- 12 -
V. Routine maintenance .....	- 13 -

# FORWARD WORD

Thank you for choosing 15.8inch KIOSK POS cash register. In order to enable you to use the cash register better, please Read this manual carefully before installing and using the machine, so as to have a preliminary understanding of the machine and follow the necessary operations procedures.

This manual introduces the overall performance of 15.8inch KIOSK POS cash register and lists the main functions of each optional accessory. parameters ; the packing list and installation are described, and the user can check the accessories and install the machine according to this instruction; Introduces the method of power-on inspection so that users can check whether the machine is damaged during transportation; Faults caused by improper use and their troubleshooting methods; a brief introduction to the hardware maintenance of the machine is given in the appendix Provides driver function libraries for cash drawers and customer display boards under various operating systems.

When you have any questions about the machine, please feel freely to contact with our technical.

**STATEMENT:**

From the packing list. For the interfaces and components that are not selected, the manual contains content for the above models, components and interfaces. will be invalid. All information in this article is subject to the data at the time of publication and is subject to change without prior notice; For further technical support and latest information, please contact your nearest dealer or customer service center.

The company is not responsible for the following actions:

Damage caused by use and maintenance not under the conditions of this instruction;

Damage or problems caused by options or consumables (parts not provided or approved by our company) are not with the consent of the company, there is no right to modify or change the product.

**WARNING:**

1. Static electricity may damage the host integrated circuit.
2. Improper replacement of the battery may cause an explosion hazard. Only replace with the same or equivalent type of battery recommended by the manufacturer.
3. Dispose of used batteries according to the instructions of the battery manufacturer.

**STATEMENT:**

This is a Class A product, in a living environment this product may cause radio interference. in this situation In some cases, users may be required to take practical measures.

## Toxic and Hazardous Substance Name and Content Table

Material Information Sheet part name	Hazardous substances					
	lead ( mg/kg)	HG ( mg/kg)	cadmium ( mg/kg)	Hexavalent chromium ( mg/kg)	PBBs_ ( mg/kg)	polybrominated di Phenyl ether ( mg/kg)
Power supply (power adapter)	x	o	o	o	o	o
Hard disk and data cable	x	o	o	o	o	o
memory	o	o	o	o	o	o
fan	o	o	o	o	o	o
Main board and control board	x	o	o	o	o	o
Wire and cable	o	o	o	o	o	o
Enclosures , hardware and screws	o	o	o	o	o	o
Plastic parts, labels, mats	o	o	o	o	o	o
plastic case	o	o	o	o	o	o

**O** : Indicates that the content of the toxic and hazardous substance in all the homogeneous materials of the part is GB/T 26572-2011 The limit requirements stipulated in the standard are below .

**X**: Indicates that the content of the toxic and hazardous substance in at least one homogeneous material of the part exceeds GB/T 26572-2011 Limit requirements stipulated in the standard.

*Note: Most of the components in this product are made of non-toxic and harmless environmental protection materials, and contain toxic and harmful substances or element components are unable to realize toxic and harmful substances or elements due to the limitation of global technological development level alternative .*

# 15.8inch KIOSK cash register

1. During installation and use, a three-hole power socket with CCC certification and UPS power supply that meet national standards must be used. The ground wire is required to be well grounded, and the power supply voltage is required to be stable. Avoid contact with other frequent startups or power supplies. Equipment with frequently changing flows shares lines, outlets, and UPS power.
2. Never spill any liquid, or drop it into any object.
3. Do not press heavily, vibrate violently, shake or hit the cash register hard.
4. Do not switch the power on and off frequently, as frequent switching will easily cause impact on the machine.
5. Do not plug or unplug any live parts and peripherals of the cash register when it is charged.
6. The cash register must use qualified printing paper and printing ribbon.
7. Do not extend the cable or replace its parts arbitrarily, please contact our company or agent if necessary.
8. The machine should be operated in a dry, ventilated, clean environment and away from sunlight. It is best to keep it between 5-35°C, and the relative humidity of the environment is best kept between 20%-80%.
9. The air outlet of the main engine cannot be blocked, and it is required to have an upward and outward opening with an opening area of not less than 0.01m<sup>2</sup> Outlet channel.
10. When using a USB flash drive, please make sure that the USB flash drive is virus-free.
11. The machine should be managed and used by a special person, and training should be carried out before use. Do not let unfamiliar persons operate the machine.
12. The machine should be maintained regularly, including: function testing, external cleaning of the whole machine, printer and keyboard cleaning, main Machine interior cleaning, printer and cash drawer lubrication, cable and plug inspection, hard disk inspection and cleaning, virus Scan and clean. For details, see the fifth part, maintenance schedule:

Maintenance item \ Schedule	before use	every week	first month	first quarter	quarterly thereafter
Structural and functional testing	●			●	●
Machine exterior cleaning, printing Machine and keyboard cleaning	●	●			
Host internal cleaning, printing Machine and cash drawer lubrication				●	●
Cable and Plug Inspection	●		●		●
Hard Disk Check and Cleanup	●		●		●
virus scan and clean	●	●			

● Indicates the maintenance items that need to be carried out on the current date.

13. The weekly external cleaning of the whole machine and the cleaning of the printer can be operated by the user. The method is: When the power is on, use a soft dry cloth to wipe the exterior of the machine, open the paper compartment door of the printer through the button or key , take out the printing paper, and use an Opening width less than 7 mm The vacuum cleaner in the printer head and the main unit dust at the air inlet , then install the printing paper correctly and close the paper compartment door , be careful not to use alcohol, vapor Chemicals such as oils and thinners.
14. If you accidentally spill liquid or fall into debris, please shut down and cut off the power immediately, remove the battery, and dry the liquid body and remove sundries. For spilled corrosive liquids, wash them with clean water and then dry them. Remove the battery and reset the CMOS after booting.
15. When the machine breaks down and the problem cannot be solved according to the established procedures, please notify our company or agent for consultation Send personnel to check, and do not open the case by yourself.
16. When there are safety failures such as: abnormal smell, abnormal sound, leakage and other failures, the power supply should be cut off immediately, and the equipment management should be notified.  
The management department reported it in a timely manner so that it can be dealt with as soon as possible.
17. When the cash register is not in use, it should be turned off and the power supply should be cut off, and the protective cover should be put on.



# 1. Machine introduction

15.8inch KIOSK POS cash register is an integrated touch POS newly developed by our company, and can be connected to Keyboard and mouse etc.

## 1. Model description

P690 \*\*\*\*\*

Note: The "\*" behind the model number represents different configuration requirements or none.

## 2. Features of 15.8inch KIOSK cash registers

- The highly integrated appearance design reduces the occupied area of the cash register.
- Good front and rear convection heat dissipation system design ensures the reliability of operation.
- The viewing angles of the main display and the secondary display can be adjusted up and down.
- After 48 hours of high-temperature aging and 3 full-function tests (including the final electrical safety test) before leaving the factory full test).
- 100V \_ AC to 240V AC voltage input range.
- Strict electromagnetic compatibility design.
- Flexible peripheral interface design to adapt to applications of different formats.

## 3. This product adopts an open architecture, which has many advantages

The recommended operating systems are: Android / WIN7/8/10 and Linux.

- Can be adapted to all software of the customer.
- External USB and serial port peripherals can be connected.
- main components are Android industrial control standard components: such as the main board, imported new DDR3/EMMC particles, pure copper cables, etc.

## 4. Share 15.8 inch series POS Configuration instructions for cash registers

main performance indicators of each configuration of 15.8inch KIOSK POS cash registers are as follows:

## **a. Hardware Configuration**

### **Android Configuration—15.8inch- A1**

CPU : RK3399(Cortex-A72 (2 cores ) +Cortex-A53 (4 cores )

operating system : Android 11.0

show : 16 primary touch screens/16 secondary screens/1920\*1080

Touch : capacitive multi-touch (G+G)

Memory : 4G \_ LP DDR 4

hard disk : 64G EMMC \_

printer : Built-in 80m automatic paper cutting high-speed thermal printer

speaker : 1 speaker 4Ω 3 W

Network : LAN ( 10M/100M adaptive )+WIFI 2.4G

Bluetooth : BT4.1

### **Windows Configuration—15.8inch- W1**

CPU: J1900 2.0GHZ (4 cores )

operating system : windows7/8/10Linux

show : 16 primary touch screens/16 secondary screens/1920\*1080

Touch : capacitive multi-touch (G+G)

Memory : 4 /8G DDR3

hard disk : 64/128/256G MSATA SSD

printer : Built-in 80m automatic paper cutting high-speed thermal printer

speaker : 1 speaker 4Ω 3 W

Network : LAN( 10M/100M /1000M adaptive )+WIFI 2.4G

### **interface--**

USB : USB\*4+ OTG\*1

serial port : RS232 \* 3 DB9 interface

Cash drawer interface : RJ11\*1

Network port : RJ45\*1 ( 10M/100M adaptive Ethernet port )

DC: 5.5\*2.5\*1 (DC12V/5A)

Audio : 3.5mm MIC \* 1

### **b . Main display and touch screen (standard configuration)**

Types of the color: TFT - LCD

Size: 15.8inch

Resolution: 1920\*1080

Interface: DP

touch screen type: 15.8inch capacitive

Touch screen surface Strength: 6H

### **c . Secondary display ( standard configuration )**

Machine size: 400\*245\*568 mm

Size:(length\*width\*height)

resolution: White +7543C

Interface: Body + White Base

## **5. Packaging form**

15.8inch KIOSK POS cash registers are standard equipped with independent pearl cotton liner and five-layer hardened corrugated packaging.

## **6. Kiosk 158 standard packing list**

1. 15.8inch KIOSK POS machine with dual screens (with touch screen) \*1
2. Power adapter\*1
- 3 . Printer Accessories

# **2. Installation instructions**

## **1 . Machine parts introduction**

Shared Series POS Cash register standard models:

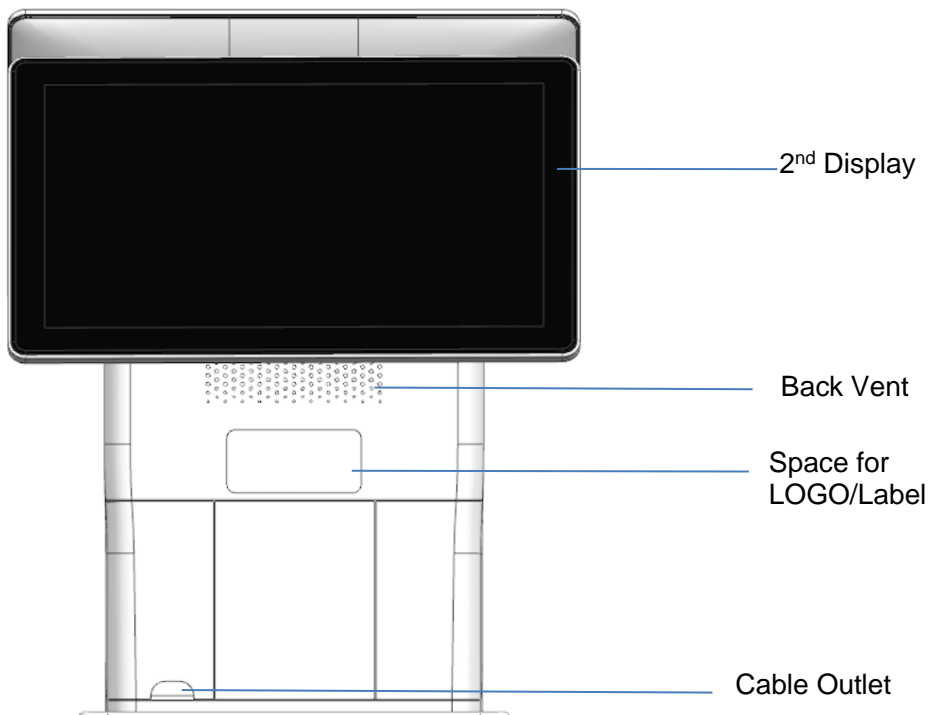
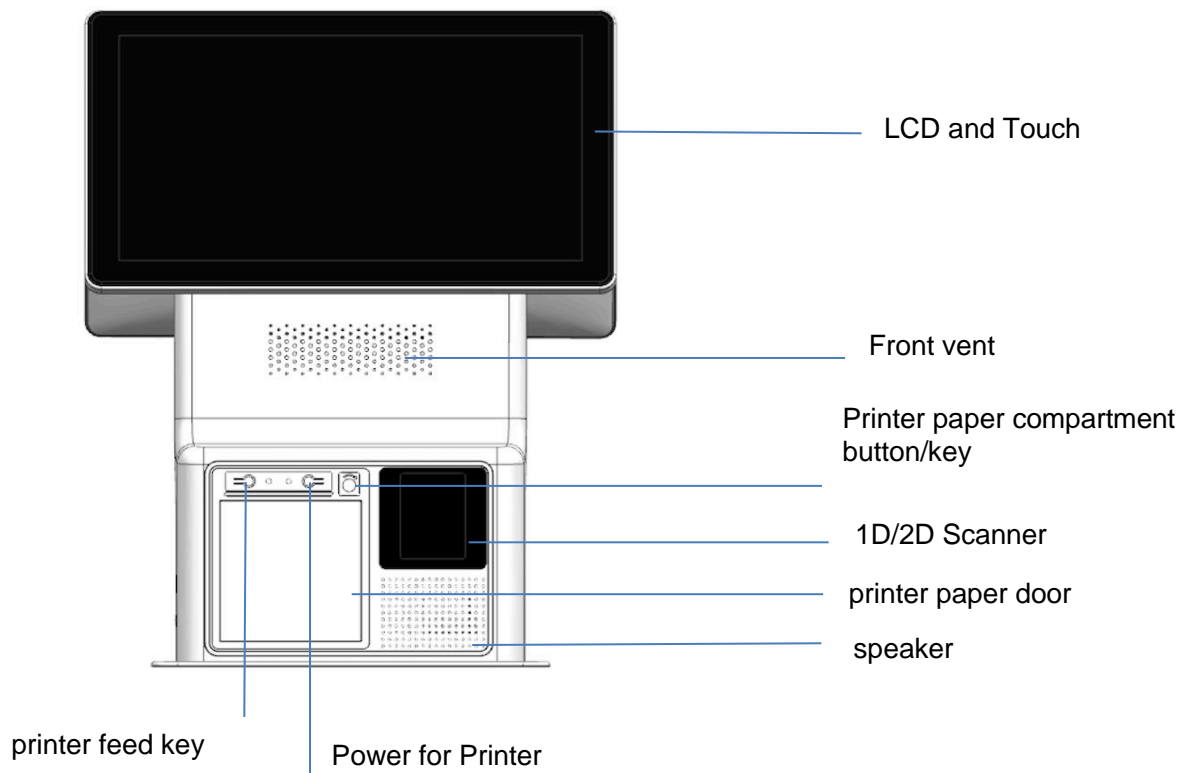

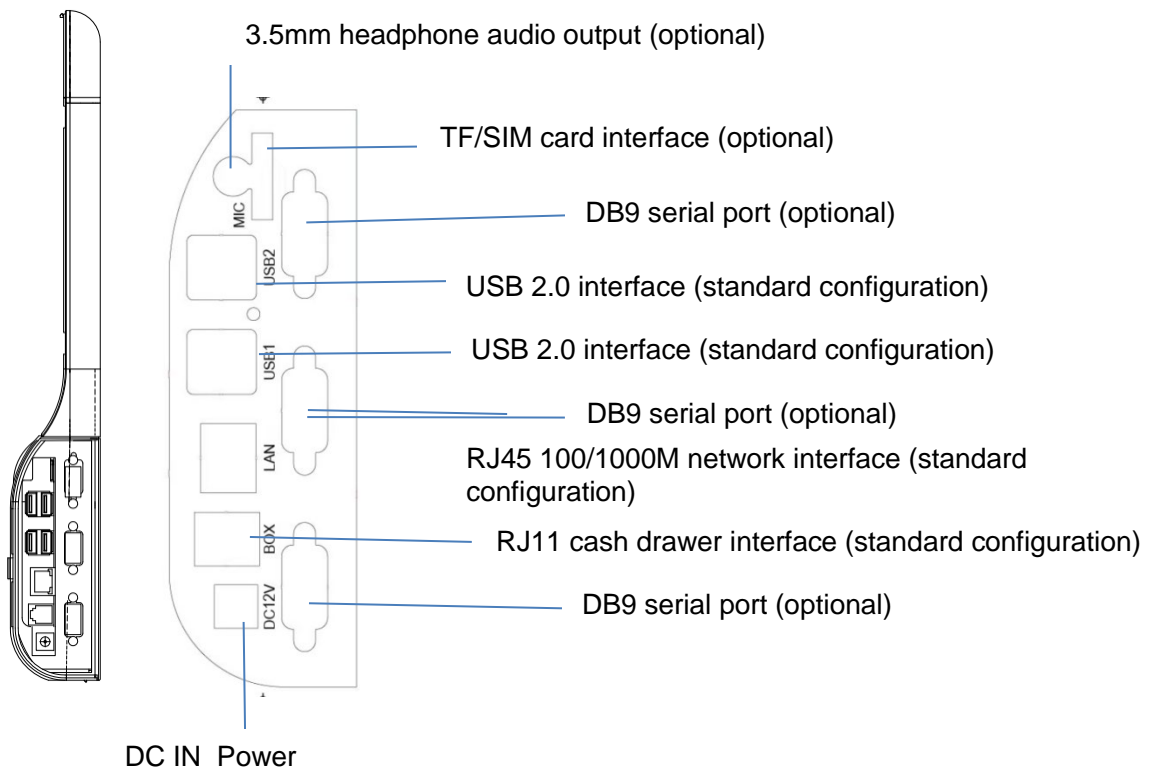
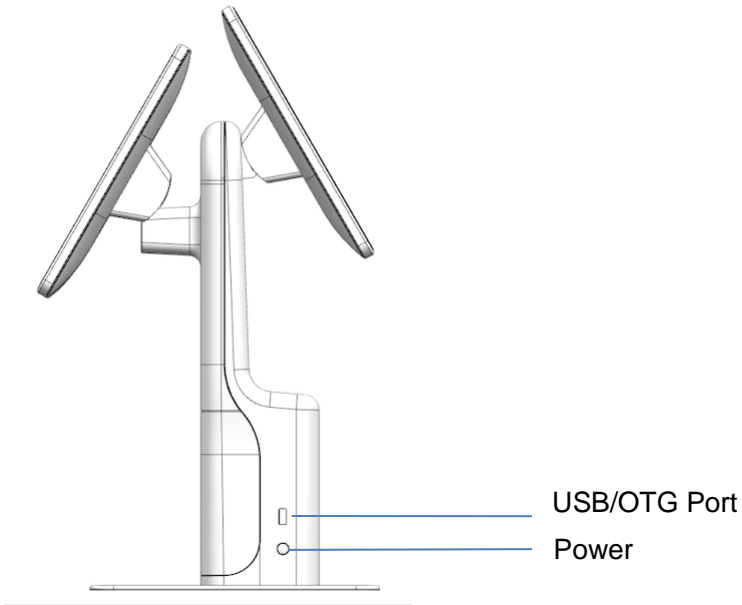

## 2. Precautions for installation and operation

- 1 ) When picking up and placing the cash register , please handle it with care.
- 2) Make sure there is no damage Only in this case can the power adapter be connected.
- 3) When the plug matches the socket, it must be inserted in place. After checking that the connection is correct, make sure the connection is secure.
- 4 ) After the installation is completed, the cables that are too long should be bundled up and placed outside the rear cover .
- 5) Choose a power socket with a national standard jack and a UPS power supply. It is required that the power plug is not easy to loosen after it is plugged in. The ground wire must be reliably connected .
- 6) If the ground wire is not grounded, it will cause the chassis to be charged and reduce the anti-interference ability of the machine. Allowed.
- 7) Installation should be carried out without power on, plugging and unplugging with power is prohibited.
- 8) When adjusting the viewing angle of the LCD , the push/pull point should be in the middle of the upper frame of the LCD .
- 9 ) Start-up sequence: After power-on, check that the indicator light of the power adapter is always on, and then lightly press the power button to start up .
- 10) Under the Android system, please use the shutdown button on the main display screen, the shutdown / restart option pops up , It is strictly forbidden to directly shut down the system without exiting the system, which may damage the system software or even the machine.

### **IMPORTANT NOTE**

- 1) Try to avoid installation or use during lightning, otherwise there is a risk of being shocked by lightning ;
- 2 ) When you find abnormal smell, overheating or smoke, please cut off the power immediately;
- 3 ) Avoid using it in a humid environment, avoid using it in a dusty or flammable and explosive environment;
- 4) This machine must ensure that the grounding of the socket power system complies with the relevant standards, otherwise it may cause personal injury.

## 3. Self-inspection of the machine

of 15.8inch KIOSK POS cash registers have been strictly inspected before leaving the factory, and have been made according to the user's configuration before shipment. Online inspection. If there is no accident during transportation, after arriving at the user, install it correctly according to the **installation instructions in the second part**. It should work normally after power on.

The power -on inspection process is:

1. Confirm that the machine has been installed correctly according to the diagram.

2. The cash drawer has been connected to the RJ11 driver interface of the cash register.

3. Check whether the power indicator light of the printer is always on, and install the printer according to the instructions in the printer manual. Printing paper, **the adhesive tape on the printing paper must be torn clean** .

5. Insert the power plug of the main unit into the power socket, press and hold the power button on the side of the main unit for 3-5 seconds, release the hand, and the buzzer will make a "beep" , and then the main display will display the boot LOGO and enter the Android desktop . At this time The cash register has been turned on normally and the next operation can be performed .

Functional check:

Start-up operation, after the power is turned on, the main unit should be able to start up normally, and the corresponding indicator lights should work.

If the above function checks are normal, it means that the functions of the host computer, printer, cash drawer, and keyboard are normal. At this time, the user can turn to the installation of the POS application software. If the above function checks are not normal, first check whether the wiring is correct. Generally, machines are purchased in batches. If the first machine fails the power-on test, there is no need to panic. You can put the first machine down first, and then test the second one. As long as one machine succeeds, other problems may be solved one by one after gaining experience. If the user still cannot make the machine pass the power-on test procedure, please contact our company in time to send personnel to the scene to deal with it. Generally, the user should not disassemble and dispose of the faulty machine casually. If someone damages it, the customer must be responsible for it.

## 4. Common troubleshooting methods

Below, we list some common faults, judgments and solutions for your reference. listed cannot Inclusive of all fault phenomena, but the user can learn the preliminary inspection and judgment methods, and then step by step from one to the other

## 5. Daily maintenance

15.8inch KIOSK POS cash register is a computer-like electronic device. To make the cash register work stably for a long time, Routine maintenance is essential. Please pay attention to the following aspects:

In order to prolong the service life of the cash register, the recommended working environment requirements:

working temperature: 5 ~ 35 degrees Celsius

working humidity: 20~ 80%

---

## MAINTENANCE METHOD:

serial number	project	operation method
1	function detection	according to the third part "Self-inspection of the machine"
2	Machine exterior cleaning	When the power is off, use a soft dry cloth to wipe the exterior of the fuselage, remove the Printer paper, vacuum with an opening width less than 7 mm Use the filter to suck the dust from the air inlet of the host, and then install the ribbon of the printer and printing paper, be careful not to use chemicals such as alcohol, gasoline, thinner products.
3	printer	Remove the printing paper from the printer , and use paper with an opening width less than 7 mm The vacuum cleaner sucks the dust in the printer head and between the keys of the keyboard.
4	Host internal cleaning	( Must be operated by professionals)
5	Printer Lubrication	( Must be operated by professionals)
6	Cable and Plug Inspection	Check whether each connector is rusted or damaged, whether it is plugged in place, and whether the screw Check whether the nails are fastened, whether the cables are damaged or seriously bent, and if so, please when replaced.
7	Storage inspection and cleanup	(operated by professionals)
8	virus scan and clean	Download the latest anti-virus software virus library, system storage and removable moving media.



