

>> USER MANUAL <<



Kiosk Series

SHENZHEN JASSWAY INFOTECH CO., LTD

Disclaimer

- ✓ Please read the instructions carefully before equipment installation and using the device.
- ✓ Do not put the product in high temperature, humid or dusty environment.
- ✓ Do not drop, crash or break down this product.
- ✓ Do not power off the device when it's formatting or upgrading, otherwise it will cause operation system error.
- ✓ Use only approved add-on enhancements.

Content

Product Description	1
Hardware Instruction	2
Installation	3
Stand Installation	4
Getting started	4
Warranty Notice	4

Product Description

JAW-K215 or K320 touch kiosk series can serve as a complete digital replacement of the menu and order system, or as an out-of-home advertising platform for consumers. Simplify and speed up the Whole Process Avoid Queuing Save Labor Costs. Make business more convenient and easy.

Overview – Specifications

SYSTEM	
Processor	Intel Celeron J4125 Quad-Core, Up to 2.70 GHz Intel Celeron J6412 Quad-Core, Up to 2.60 GHz Intel Core i3/i5 3rd, 4th, 5th, 6th, 7th, 8th High Performance CPU
Memory	2GB, DDR3L or DDR4, up to 8/16/32GB
Storage	mSata or M.2 64GB standard, up to 1TB
OS	Windows 7, Windows 10, Windows 11, POS Ready7
DISPLAY	
Type	21.5 inch / 32 inch TFT LED Backlight LCD
Resolution	1080*1920
Aspect Ratio	9:16
Brightness	500 nits
Viewing Angle	89/89/89/89 (Typ.)(CR≥10)
Touchscreen	Projective Capacitive Touch Screen
INTERFACE	
USB	2* External USB2.0
LAN	1*Gigabit Ethernet, RJ45
Power DC-IN	Input AC 100~240V/50~60hz, Output DC12V/12.5A
PRINTER	
Printing Method	Direct Thermal
Interface	Standard USB, COM or LAN Port Option
Printing Speed	150mm/s(Max)
Paper Width	79.5±0.5mm
Printable Width	72mm
Paper Roll Diameter	80mm(Max)
Cut Paper Method	Partial Cut or Full Cut
PHYSICAL&ENVIRONMENTAL	
Operating Temperature	Operating 0~60°
Storage Temperature	Storage-35°~75°
Cooling	Fanless/CPU Fan
Color	Black/White
OPTIONS & PERIPHERALS	
Scanner	2D scanner
Payment Terminal	Reserved Space for Payment Terminal(Size Customizable)
Wifi	Mini PCIe for Wireless LAN(Optional)
Bluetooth	Bluetooth 4.0 protocol(Optional)
Speaker	2*3W Speakers(Optional)
Camera	5.0MP Front Camera(Optional)

Hardware Instruction

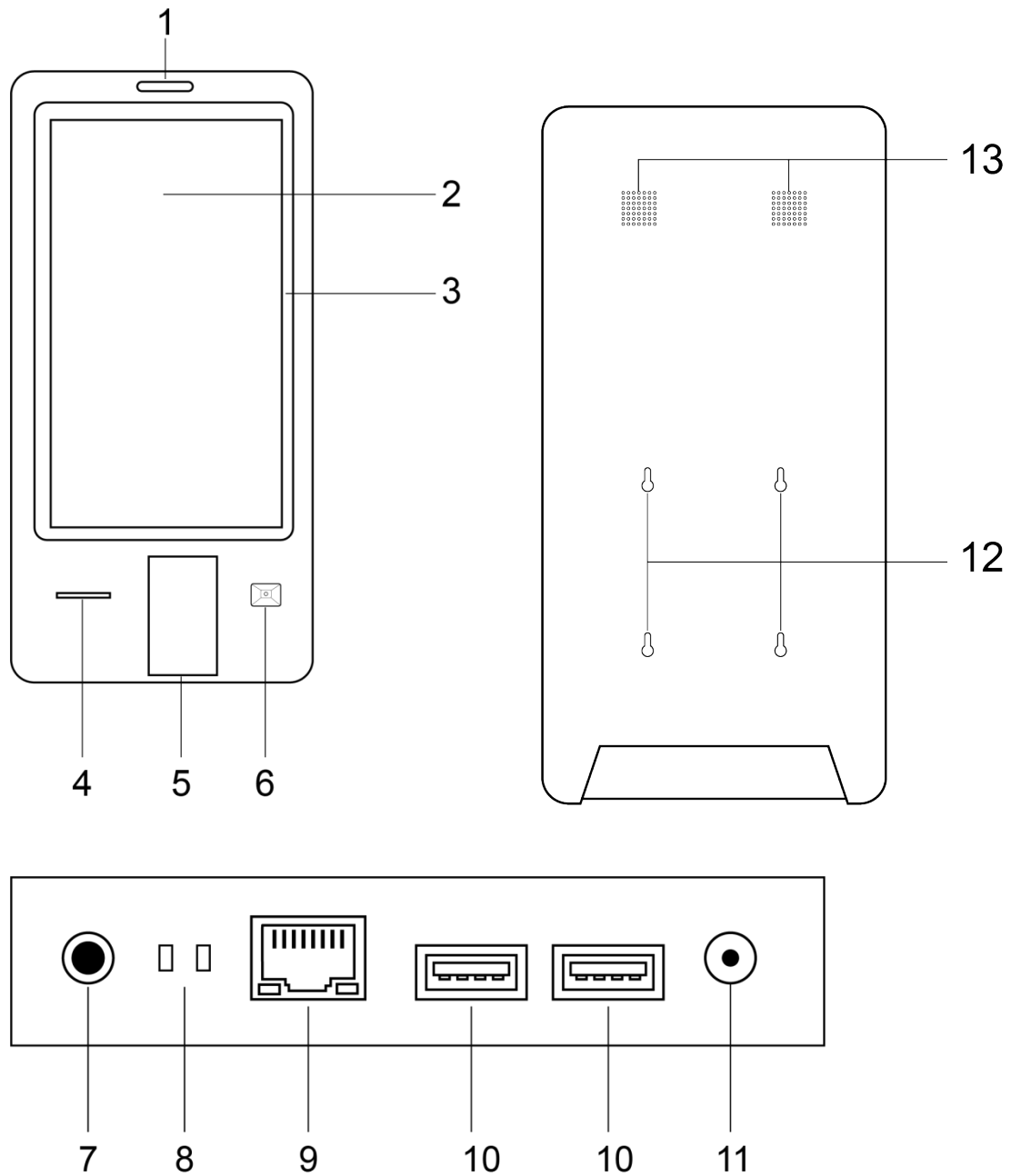

1. 5.0MP Front Camera (Option)
2. 21.5 or 32 inch Display
3. 21.5 or 32 inch P-CAP Touch
4. 3 inch Thermal Printer
5. Credit Card Holder
6. 2D scanner
7. Power Button

8. AC Power Socket
9. LAN Port
10. 2*USB Ports
11. Wi-Fi Antenna
12. Wall Mounting Bracket Holes
13. Fan Exhaust Holes

Dimension

21.5 inch Kiosk

Unit: mm

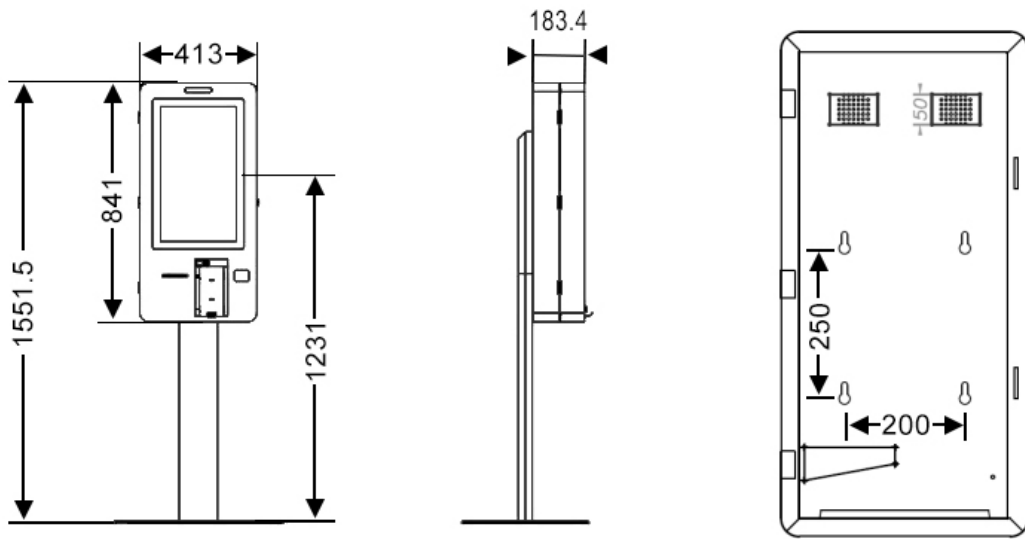

32 inch Kiosk

Unit: mm

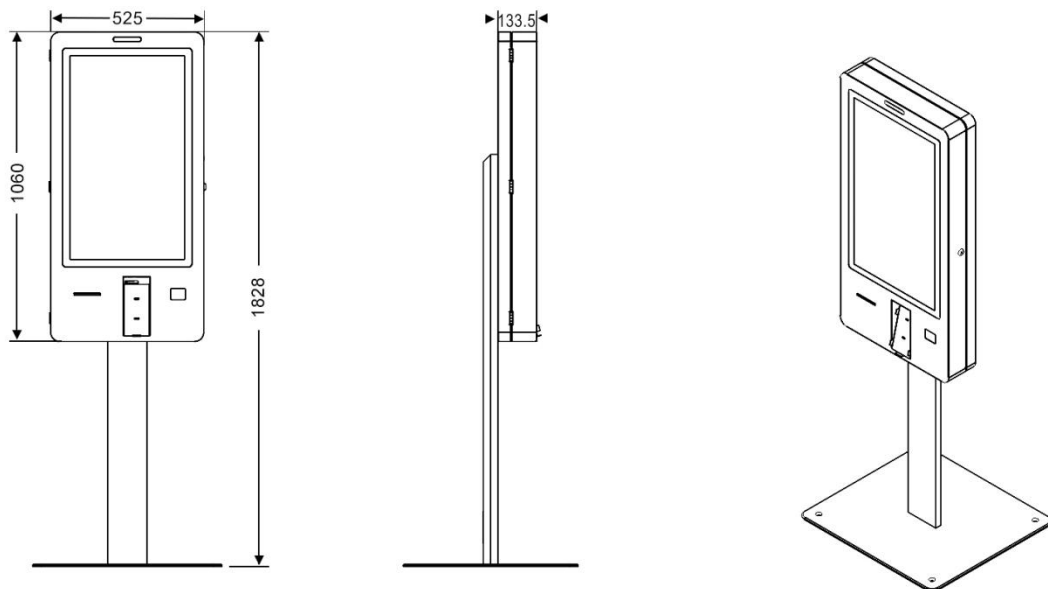

Installation

Unpacking Verify that the box contains:

- Kiosk terminal
- Stand Base (Option)
- Stand Pole (Option)
- Accessory Box (Include power cord, holder of credit card reader, screws, kiosk key)

Remove all protective materials from the device.

Inspect the device for any damage during shipment.

Contact us immediately if system has damage and/or missing items as listed above, keep the shipment carton for logistics claim.

Stand Installation

Step 1. Place the stand base and pole horizontally and assembly the stand base with stand pole by locking the screws from bottom.

Step 2. Place the assembled stand vertically, and then put it on the floor or flat ground. Install 4 screws to the holes on stand pole, but do not tighten.

Steps 3. Hang the Kiosk to the 4 screws on stand pole, tighten the screws.

Steps 4. Touch and test the kiosk, make sure it is stable and do not shake during operation.

Getting started

1. Connect Ethernet cable through RJ45 connector. The network cable could be hidden inside the pole. And the other side of cable comes out from the reserved position on the stand pole.

2. Connect power cord with kiosk, the power connector could also come out from the reserved position on the stand pole, and then connect to power source.

3. Open kiosk with the key, pull the printer latch to put the receipt paper inside. Place the paper to paper outlet. Close the door of kiosk and lock it.

4. Press and release the power button, display will be on after beeping sound came from inside mainboard. Barcode scanner will also start working with notification tone and LED light.

Warranty notice

Thank you for purchasing the company's products! The warranty regulation is formulated hereby in order to protect your legal rights and interest and remove your future worries and improve after-sale service for customers. You are asked to read carefully and propose valuable opinion and suggestion. Respected users:

I . The company's products enjoy free warranty of 18 months since the Shipment date. If it exceeds the warranty period, reasonable service expense and material cost will be charged.

II. The product for repair should be packed and transported properly. If there is any damage or loss during the process of transportation, our company will not take responsibility.

III. Our company has the right to refuse to provide service or charge material and service cost where appropriate with occurrence of the following items within the free warranty period.

1. Product failure or damage caused by improper use of users;

2. The accident of burning caused of electric shock or improper installation;

3. Damage caused by dismantling of non repairmen.

4. The label indicating fragile product is damaged.

IV. Please read the user manual carefully before the company's product is installed and used.

V . The warranty card must be stamped with seal and indicate the date by the selling unit to ensure your rights and interest.